

Keyword: Double complex contact,Zero arc(No Arc Chute),distinct on and off position indecator,padlock function etc

XQ5 Series Automatic Change-over switch

Type & Meaning

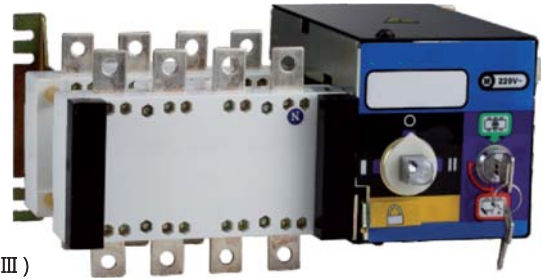
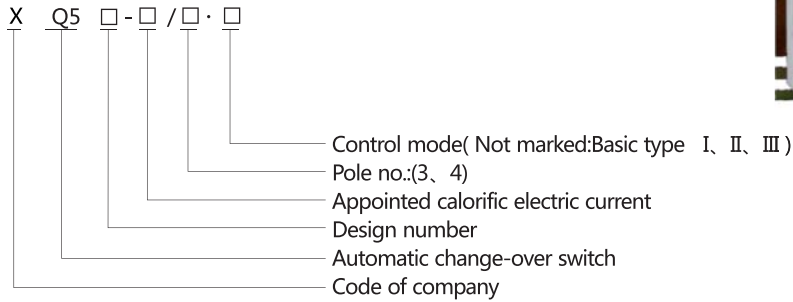

Example for model selection

XQ5-100/4.III~400V In50A

Automatic change-over switch, Conventional thermal current is 100A, AC rate voltage 400V,rate current 50A,4poles(3 poles+on and off neutral pole),Suitable for automatic change and automatic recovery of municipal power oil generator power supply system.

Conform Standard

XQ5 Series Automatic Change-Over Switch Complies With The Following Standards:

IEC60947-1(1998) 《Low-voltage switchgear and controlgear, part one: General Rules》 .

IEC6094-3(1999) 《Low-voltage switchgear and controlgear, switches, disconnectors, switch-disconnectors and fuse-combination units》 .

IEC60947-6(1999) 《Low voltage switch equipment and control equipment multi-function-switch automatic change-Over switch electrical device》 .

National Standard:

GB/T14048.1-2002 《Low-voltage switchgear and controlgear,part one: General Rules》 .

GB14048.3-2002 《Low-voltage switchgear and controlgear,switches,disconnectors,switch-disconnectors and fuse-combination units》 .

GB014048.11-2002 《Low voltage switch equipment and control equipment multi-function-switch automatic change-over switch electrical device》 .

Main Technical Parameters

•XQ5-100~1600A

XQ5-100-1600A series automatic change-over switch electrical properties and mechanical properties

Conventional thermal current Ith A			100AXQ51								
Rated current In(A)			16A	20A	25A	32A	40A	50A	63A	80A	100A
Rated impulse withstand voltage Ui(V)			500	500	500	500	500	500	500	500	500
Dielectric strength(V)			3000	3000	3000	3000	3000	3000	3000	3000	3000
Rated surge-resistant voltage Uimp KV (installed category IV)			6	6	6	6	6	6	6	6	6
Rated Working current Ie(A)	400V	AC-31	16	20	25	32	40	50	63	80	100
		AC-33	16	20	20	25	32	40	40	63	80
		AC-35	16	20	25	32	40	50	63	80	100
	220V	DC-31	16	20	25	32	40	50	63	80	100
		DC-33	16	20	20	25	32	40	40	63	80
		DC-35	16	20	25	32	40	50	63	80	100
Motor power P(400V)KW			8	10	15	15	20	25	30	30	32
Rated short-time withstand current(kA Rms)0.1S/1S			9/5	9/5	9/5	9/5	9/5	9/5	9/5	9/5	9/5
Rated Breaking capability(A rms)AC33 380V			125	160	200	250	320	400	500	640	800
Rated making capability (ARms)AC33 380V			160	200	250	320	400	500	630	800	1000
Rated short-current making capability Icm (KA peak value)			8	8	8	8	8	8	10	10	10
Mechanical durability(number of cyclic operation)			10000	10000	10000	10000	10000	10000	10000	10000	10000
Electric durability	Cosφ=0.65Ac33		2000	2000	2000	2000	2000	2000	2000	2000	2000
Change-over time	I-0-II or II-0-I(S)		1.0	1.0	1.0	1.0	1.0	1.0	1.0	1.0	1.0
	I-0 or II-0(S)		0.5	0.5	0.5	0.5	0.5	0.5	0.5	0.5	0.5
Power consumption of electrical control	24V(DC)(W)		25	25	25	25	25	25	25	25	25
	220V(AC)(W)		25	25	25	25	25	25	25	25	25
Moment of operation(Nm)			1	1	1	1	1	1	1	1	1
Weight(kg)	3Poles		5.6	5.6	5.6	5.6	5.6	5.6	5.6	5.6	5.6
	4Poles		5.8	5.8	5.8	5.8	5.8	5.8	5.8	5.8	5.8

XQ5SERIES AUTOMATIC CHANGE-OVER SWITCH

Main Technical Parameters

1.XQ5-100-1600A series automatic change-over switch electrical properties and mechanical properties

100A					160A		250A		630A		1600A			
20A	40A	63A	80A	100A	125A	160A	200A	250A	400A	630A	800A	1000A	1250A	1600A
500	500	500	500	500	500	500	500	500	500	500	500	500	500	500
5000	5000	5000	5000	5000	5000	5000	5000	5000	8000	8000	10000	10000	10000	10000
8	8	8	8	8	8	8	8	8	12	12	12	12	12	12
20	40	63	80	100	125	160	200	250	400	630	800	1000	1250	1600
20	32	40	63	80	125	160	200	250	340	536				
20	40	63	80	100	125	160	200	250	400	630	800	1000	1250	1600
20	40	63	80	100	125	160	200	250	400	630	800	1000	1250	1600
20	32	40	63	80	100	125	160	200	315	500				
20	40	63	80	100	125	160	200	250	400	500	800	1000	1250	1600
10	20	25	30	32	63	80	100	132	220	280				
9/5	9/5	9/5	9/5	9/5	20/10	20/10	25/12	25/12	40/20	50/25	90/50	90/50	90/50	90/50
160	320	500	640	800	1000	1000	1600	1600	3200	3200				
200	400	630	800	1000	1250	1250	2000	2000	4000	4000				
8	8	10	10	10	12	12	17	17	30	30				
1000	10000	10000	10000	10000	10000	10000	10000	10000	5500	5500	4000	4000	4000	3000
1500	1500	1500	1500	1500	1000	1000	1000	1000	500	500	500	500	500	500
0.5	0.5	0.5	0.5	0.5	1.0	1.0	1.1	1.1	1.2	1.2	1.2	1.2	1.2	1.2
0.3	0.3	0.3	0.3	0.3	0.6	0.6	0.7	0.7	0.8	0.8	0.8	0.8	0.8	0.8
50	50	50	50	50	75	75	75	75	90	90	90	90	90	90
50	50	50	50	50	75	75	75	75	90	90	90	90	90	90
15	15	15	15	15	22	22	30	30	45	45	55	55	55	60
					8.2	8.2	10.4	10.4	17.8	19	28	31	31	34
4.2	4.3	4.4	4.5	4.5	8.7	8.7	11.3	11.3	20.2	22	32	36	36	40

2.XQ5-800~3200A basic type series automatic change-over switch electrical properties and mechanical properties

Conventional thermal current Ith A		800A	1000A	1250A	1600A	2000A	2500A	3200A	
Rated impulse withstand voltage Ui(V)					1000V				
Rated surge-resistant voltage Uimp KV					12KV				
Rated Working voltage Ui(V)					AC440V				
Rated Working current Ie(A)	AC-31	800	1000	1250	1600	2000	2500	3200	
	AC-33	800	1000	1000	1000	1250	1250	1250	
	AC-35	800	1000	1000	1250	2000	2000	2500	
Rated making capability					10Ie				
Rated breaking capability					8Ie				
Rated restrict short circuit current KA			100	120	80				
Rated short-time withstand current Is		26KA	50KA				55KA		
Change-over time I-0-II or II-0I(s)				1.2S		2.4S			
Power supply voltage control					DC24V, 48V, 110V AC220V				
The energy consumption of the motor	Rated control voltage	Sartup	400W	400W			600W		
		In gear	90W	98W			120W		
Weight (kg)		4poles	32	36	40	49	95	98	135

Performance and characteristic

- It adopted double complex contact, horizontal and vertical type frame basically, it have come to 'Zero' arc(No Arc Chute);
- It adopt reliable machine interlock and electric interlock, the execu-tive union parts adopt independency overload disconnect switch,it makes more reliable and safety;
- Adopt 'zero' technique, it can force to set 'zero' under emergency situation(break off two way power supply at the same time),meet the requirement of fire protection linkage;
- Operate overload disconnect switch change over adopt singleness electromotor drive, switch over smooth and reliable, no noise, little wallop;
- Operate machine drive motor use only under the executive overload disconnect switch change over instanecus current across,outstanding energy saying;
- Perform overload disconnect switch with mechanism interlock device, it ensure the common use,standby power working reliable and not interference;
- Distinct On and Off position indicator padlock function ect.,safe realize the isolator between electric power and overload;
- High security, high automatization, high reliability, use life more than 8000 times;

XQ5 Series Automatic Change-over switch

- Machine & Electricity perfect design, On-Off change-over nicely agility smooth, adopt international advanced logical control technique, high anti-interference and no interference outside;
- It include main power close, standby power separate; main power separate; standby power close; main standby power all break off and steady working(I-0-II)
- Easy installation, control loop adopt terminal connection and insert.
- Four kind of operation function: emergency manual operation electromotion remote control operation automatic control stage emergency off operation automatic control operation.

Product Usage

XQ5 Series automatic change over switch mainly suitable for distribution or electromotor network, which under AC 50Hz, rated voltage 380V, rated voltage DC220V, rated current 16-1600A, main power and standby power and standby power or mutual standby power change over system or city power and generator group overload switch-over. At the same time, it can operated under un-frequency On and Off circuit act as disconnecter.

Such products are widely used at the field of important power supply site, which transport, distribution power supply system and automatization System. For Fire proection、Ho-spital、Bank、Buding etc., Which doesn't allowed power off.

Control Characteristic

- The switch has 3poles or 4poles(3poles+on or off neutral pole).
- 27 current grades can be divided into 16A 20A 25A 32A 40A 50A 63A 80A 100A 125A 160A 200A 225A 250A 315A 350A 400A 450A 500A 630A 800A 1000A 1250A 1600A 2000A 2500A 3200A.
- Basic Type: Main-standby power, self-cast, self reset.
- Type I 100A below, city power-city power self-cast, self reset Tow way power three phase short phase testing; Above 125A, City power-
- City power main and Standby or mutual power can do selection self-cast two way power three phase checking.
- Type II : City power-City power main and standby or mutual power supply can do selection(that is self-casting self reset or self-casting without self reset),two way power three phase and lack phase, overload voltge checking.
- Type III: City power-Oil machine, self casting self reset,two way power supply three phase and lack phase, overload voltage, oil machine frequency testing.

Basic Type switch control characteristic:

- Suitable for two way main and standby power system, self casting and self reset;
- It can expand function by outer connection.

Type I switch control characteristic:

- 100A below;
A: Suitable for two way main and standby power system;
B: It will switch on to the standby power supply circuit after switch delay(setting range 1~16S)when the main power supply circuit short circuit and loop(switch off or short phase).

C:When main circuit loop recovery and normal,the switch delay(setting range 1~250S)automatic switch on to the main circuit.

- 125A above

A:It suitable for main power system or mutual standby power system of two way city power.

B:When the switch selected as self casting and self reset(that is main & standby type),When main power circuit loop caused any fault(power off、 short phase);switch delay (setling range 1~46S)auto switch on standby power supply circuit loop;when the main loop recovery to normal circuit,the switch didn' t switch on to route I,only when the route II caused faulty; the On-Off delay(setting range 1~120S) automatic switch on to power supply circuit I.

C:When the switch atthe function of self casting and with out self reset,(mutual power standby type),when loop I have power supply fault (bresk off、 short phase);the On-Off delay(setting range 1~16S) automatic switch on to the circuit II;when the circuit I recovery normal, On-Off delay(setting range 1~120S)automatic switch on to circuit loop II.

- Select the best power supply circuit through terminal connection.

Type II switch control characteristic:

- It suitable for two way city main power or mutual standby power supply system.
- When the switch select to be self casting and self reset function, the On-Off delay(setting range 1~16S)automatic switch on to standby power supply circuit when the main power supply loop caused power fault. Once the main power, supply circuit come to normal, switch delay (setting range 1~120S)auto change to the main power supply circuit.
- Under the condition of switch at self casting and without self reset function, when power circuit I cause fault(short phase、 overload voltage): On-Off delay(setting range 1~16S)auto-matic switch on route II power supply; when circuit I, recovery normal, the switch doesn' t change back to circuit I, but only when the circuit II caused fault, On-Off delay(setting range 1~250S)automatic switch on to loop I.
- Select the best power supply circuit through terminal connection (Above 125A)

Type III switch control characteristic:

- It suitable for city power supply system of main power supply、 standby power supply of generator group.
- When the city power occur fault,On-Off control primary indicate the signal to start oil machine, after the On-Off delay 3S,the switch to postion " 0", delay again(warm-start time setting range 1~250S) automatic switch on to city power supply, when switch delay a gain (warm-start time setting range 1~250S)automatic switch on to oil-machine circuit power supply.
- when the city power recovery normal, the On-Off delay(setting range 1~250S)automatic switch on to city power supply, when switch delay again(setting range 1~250S), the controller send out the signal of indication to off the oil-machine.
- City power, oil-machine have the function of three phase short phase, three phase overload voltage checking, Oil machine frequency checking etc.

The above-mentioned 4 models having:

- The functions of automation, electric control and hand control.
- Delay-time 0.5s,detection signal, to prevent error action.
- Remote control "0" position.
- The key switch to select control modes.
- The switch can all be provided with RS-485 communication interface. This can be provided according to the requirements of the user.

Operation Environment

Sq5 automatic changing-over isolation switch can work reliably under the following conditions:

- Height above sea level does not exceed 2,000m;
- Ambient temperature is not higher than 40°Cand not lower than -5°C;
- Relative humidity is not larger than 95%;
- No explosion dangerous medium environment;
- No rain and snow attack environment;

Note;if the load isolation switch is expected to be used in the condition that the ambient temperature is higher than+40°C or is lower than-5°C-45°C,customers should intorm to the manufactory.

City power-oil machine automatic cut over schematic drawing

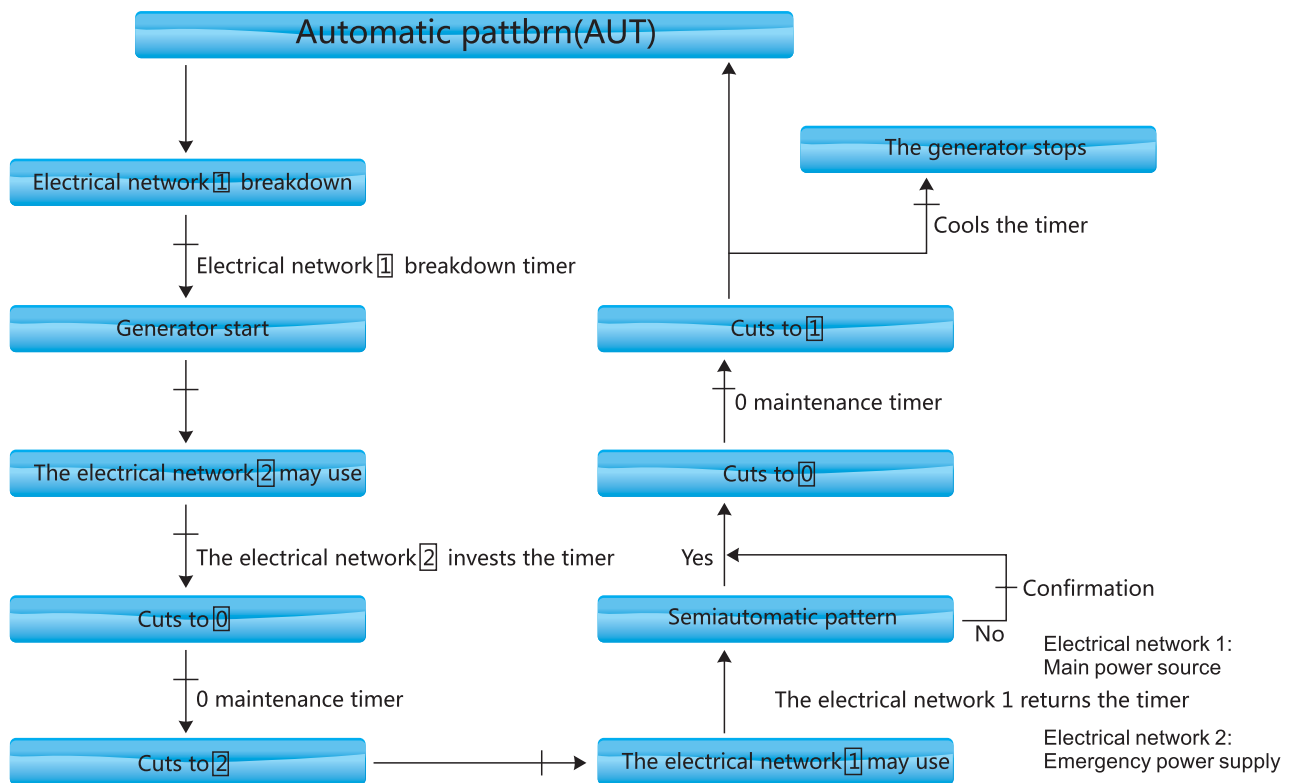

Terminal Diagram, Outline and Installation Dimension of XQ5I-100A and XQ5-63A

Terminal diagram

output connection	Zero line suitable for 3 pole N2 or N (G)	N1	Set display passive contact II 0 I common point	Start the diesel generator G	Switch body button Open to autoatically Closure for electric K	Electric/autoatic select Open to autoatically Closure for electric K	Electric control II 0 I common point
Inside of the unit	62	61	54 53 52 51	42 41	11 31	11 21	14 13 12 11

Outline and Installation Dimension

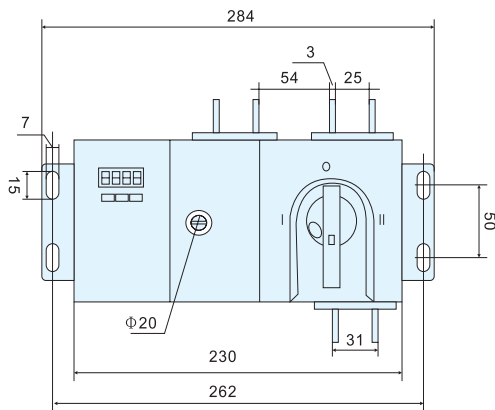

XQ51-100A

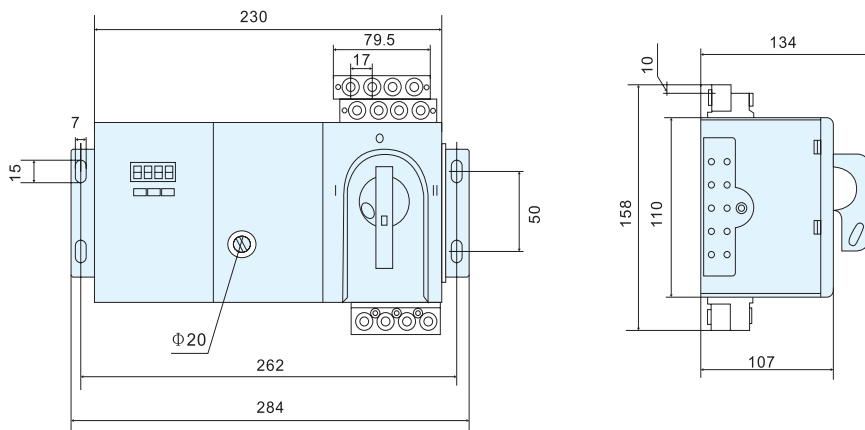

XQ52-63

XQ5-100A automatic change-over switch

External dimension and installation dimension(20~100A)

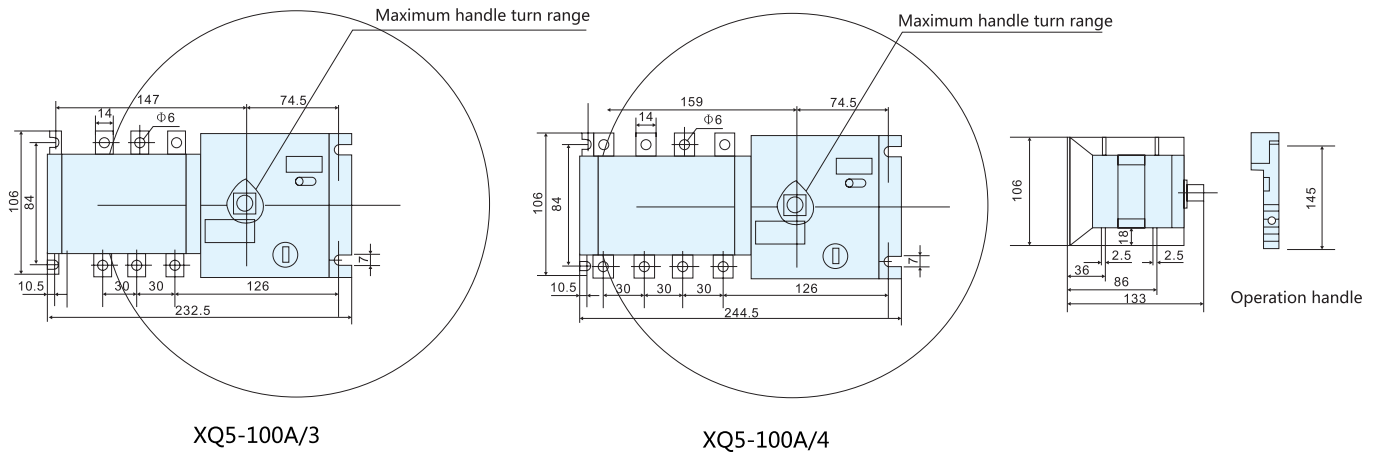

Connection chart

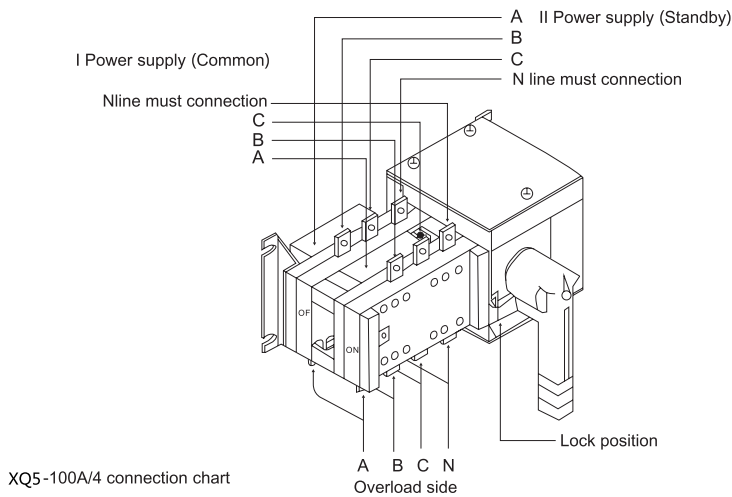
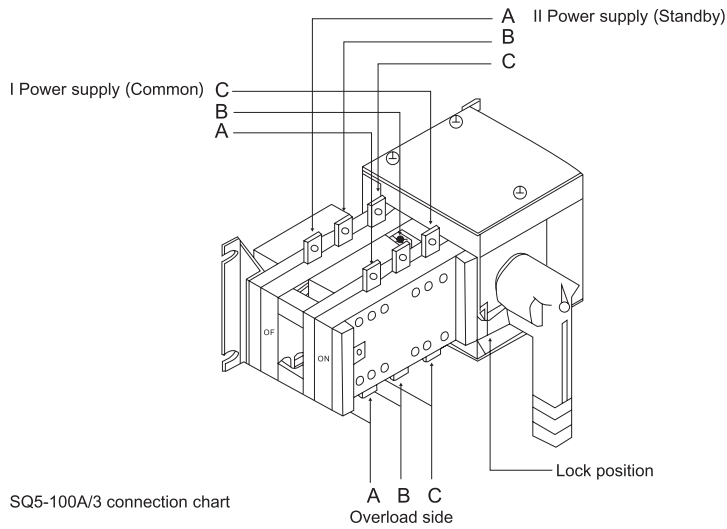

XQ5-160~1600A automatic change-over switch external dimension and installation dimension

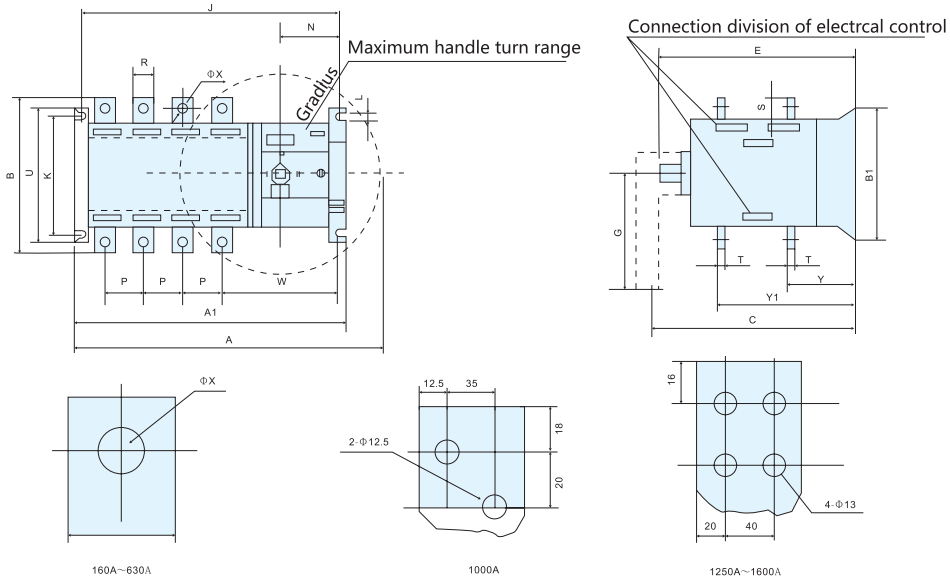

Note: The connection bridge opening and output post hole quantity is consistent.

Specification	External Dimension and Installation Dimension																			
In	A	A1	B	B1	C	E	G	J	K	L	N	P	R	S	T	U	W	ΦX	Y	Y1
125A/3	376	283.5	135	134	261	208	166	262.5	78/108	7	87	36	20	25	3.5	134	155	9	56	141
125A/4	406	316	135	134	261	208	166	295	78/108	7	87	36	20	25	3.5	134	155	9	56	141
160A/3	376	283.5	135	134	261	208	166	262.5	78/108	7	87	36	20	25	3.5	134	155	9	56	141
160A/4	406	316	135	134	261	208	166	295	78/108	7	87	36	20	25	3.5	134	155	9	56	141
200A/3	416	323.5	170	134	261	208	166	302.5	78/108	7	87	50	25	30	3.5	134	164	11	60	145
200A/4	466	373.5	170	134	261	208	166	353	78/108	7	87	50	25	30	3.5	134	164	11	60	145
250A/3	416	323.5	170	134	261	208	166	302.5	78/108	7	87	50	25	30	3.5	134	164	11	60	145
250A/4	466	373.5	170	134	261	208	166	353	78/108	7	87	50	25	30	3.5	134	164	11	60	145
400A/3	455	378.5	240	208	333	270	166	358.5	176	11	103.5	65	30	40	5	208	197	12	83	193
400A/4	515	438.5	240	208	333	270	166	418.5	176	11	103.5	65	30	40	5	208	197	12	83	193
630A/3	455	378.5	260	208	333	270	160	358.5	176	11	103.5	65	40	50	6	208	197	12	83	194
630A/4	515	438.5	260	208	333	270	160	418.5	176	11	103.5	65	40	50	6	208	197	12	84	194
800A/3	871.5	524	340	250	387	319.5	448	499	212	11	88	120	60	69	8	250	198.5	12.5	84	252
800A/4	975.5	637.5	340	250	387	319.5	448	612.5	212	13	88	120	60	69	8	250	207	12.5	107	252
1000A/3	871.5	524	340	250	387	319.5	448	499	212	13	88	120	60	69	8	250	198.5	12.5	107	252
1000A/4	975.5	637.5	340	250	387	319.5	448	612.5	212	13	88	120	60	69	8	250	207	12.5	107	252
1250A/3	871.5	524	369	250	387	319.5	448	499	212	13	88	120	80	69	8	250	198.5	13	107	252
1250A/4	975.5	637.5	369	250	387	319.5	448	612.5	212	13	88	120	80	69	8	250	207	13	107	252
1600A/3	871.5	524	376	250	387	319.5	448	499	212	13	88	120	80	69	10	250	198.5	13	109	253.5
1600A/4	975.5	637.5	376	250	387	319.5	448	612.5	212	13	88	120	80	69	10	250	207	13	109	253.5

XQ5-100~1600A automatic change-over switch control and operation

- ▲ The logic control board will send out different logic commands to control the operation of the gear-motor directly directly assembled in the switch to ensure the position of the switch.
- ▲ The gear motor is made of neoprene to insulate wetness and heat, has a safety device. It will trip off when the temperature is over 110°C and when it is under over-current state, when resumes its work, the reversible reduction gear adopts straight tooth gear.

Operation

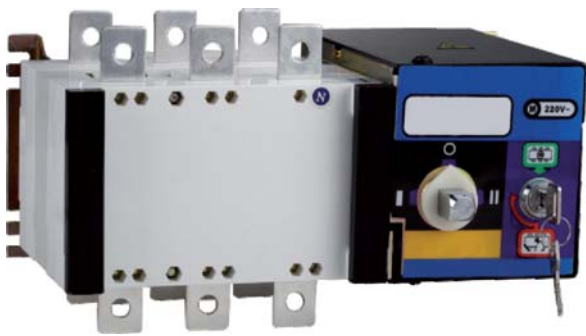

When the key is under automatic state. XQ5 will automatic change and recovers, Once manual handle is used on emergency, XQ5 will return back after delay-time 60s.

Through terminals 102、103 to force remote control turn to "0" position,optimum selection of switches 202、204.

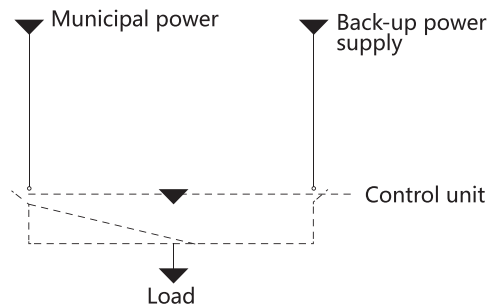

Application example: 《Normal-Emergency》 change-over



When the key is at manual operation position,to use connection terminals 202~205 to perform remote electric control.

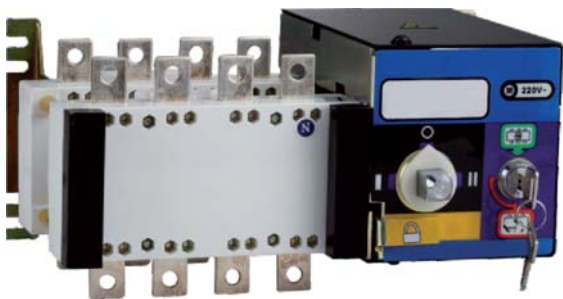

Emergency manual operation:to use emergency operation handle,to turn90. at each position.

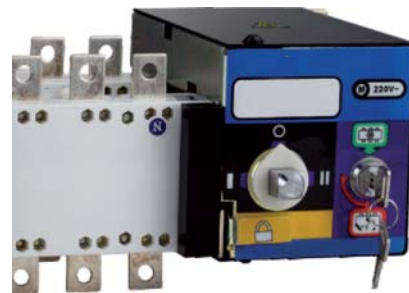

To use 1~3 locks to lock in:To keep position status,To prevent the emergency handle from being held on.

Terminal diagram of XQ5-100~1600A

Basic type terminal diagram

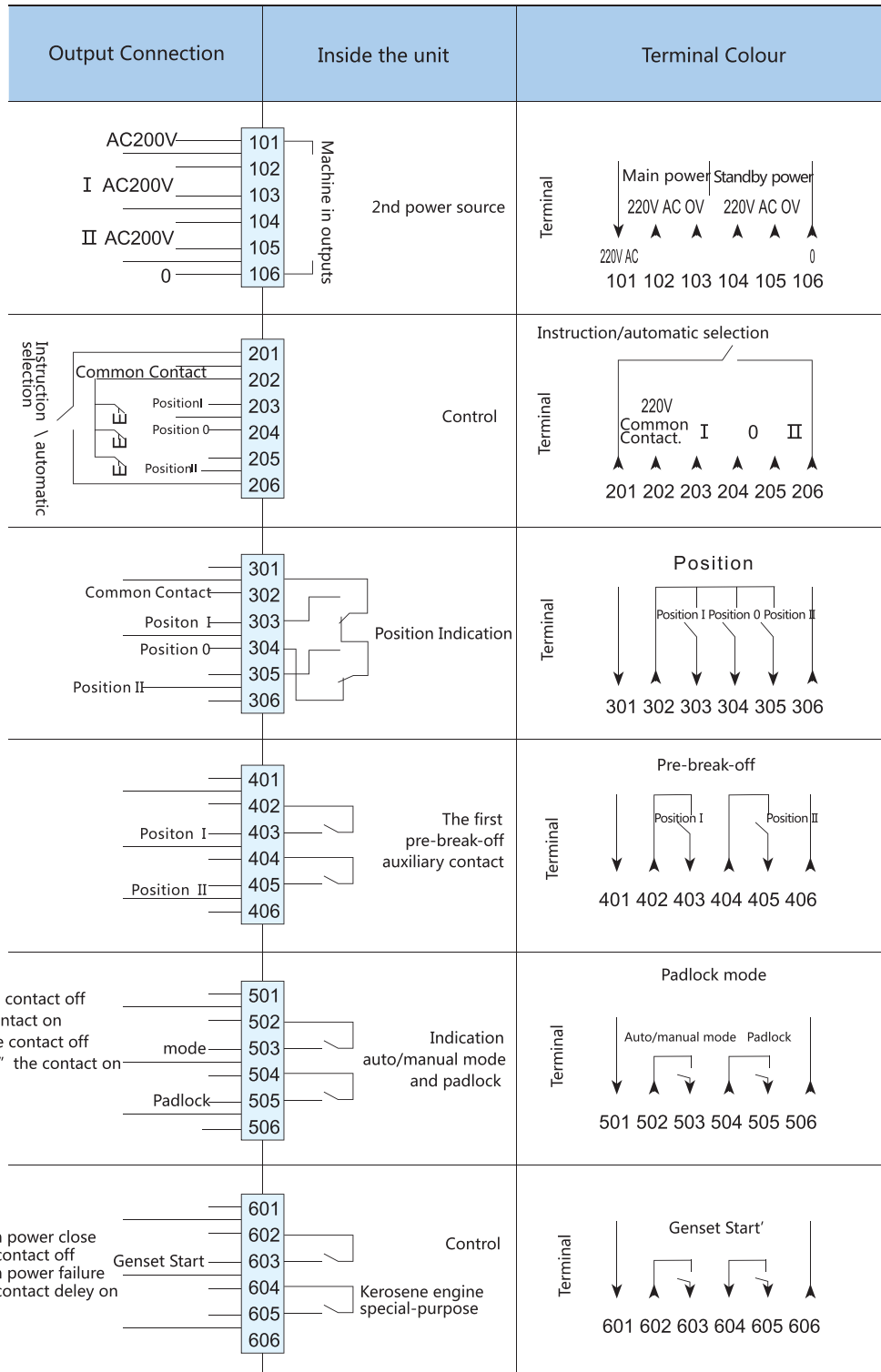

Basic type Automatic + manual(remote control)connect ways
(two city power supply circuit)

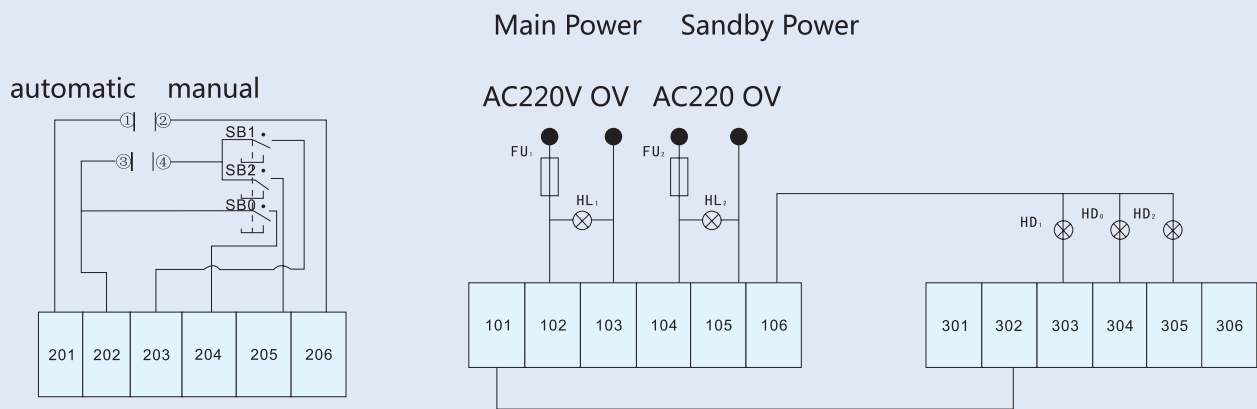

Note:SA automatic/manual function select switch

SB1:common use power、 manual push butto(No original contact)

SB2:standby power supply manual push button(No original contact)

SB0:force set "O" pushbutton(No original contact) (self-lock)

XQ5-800~3200A basic type automatic change-over switch

XQ5-800~1600A External dimension and installation dimension

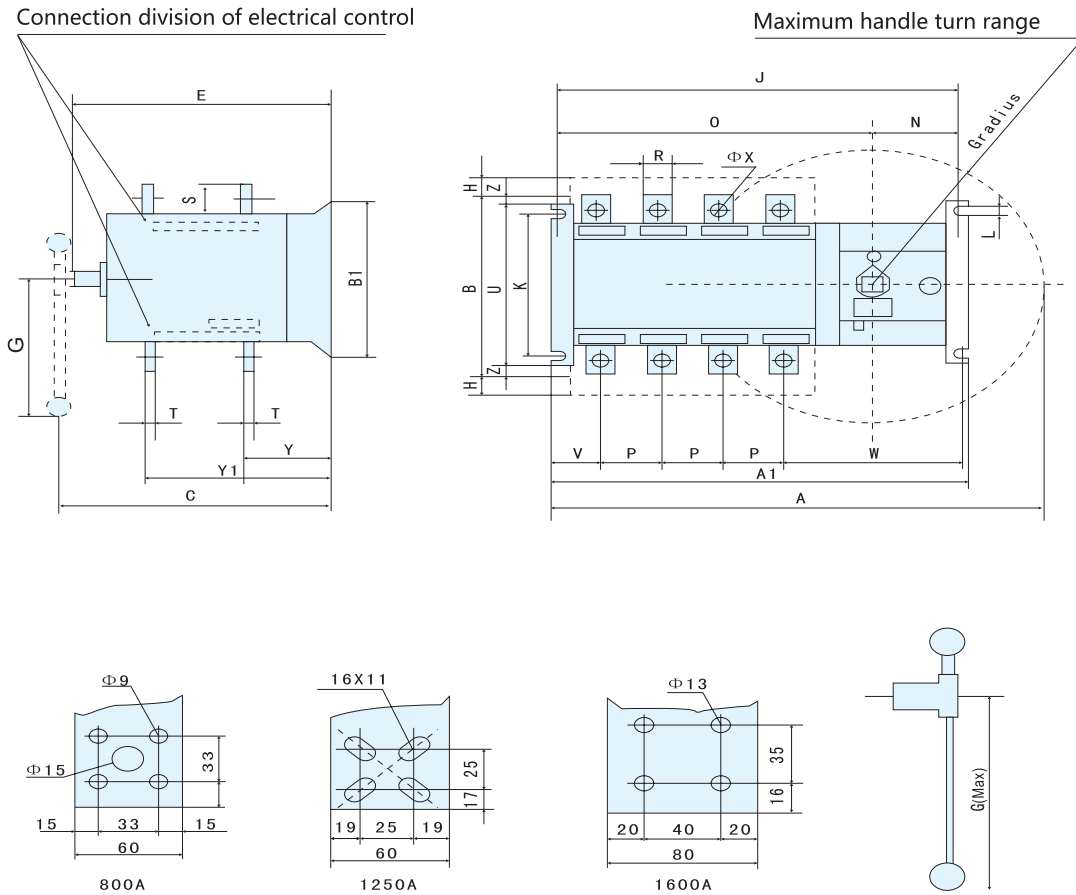

Specs	General dimension							On-Off installation					Terminal connection										
	A	A1	B	B1	C	E	G	H	J	K	L	N	O	P	R	S	T	U	V	W	Y	Y1	Z
800A	1007	633	330	250	370	321	470	65	609	220	11	85	524	120	63	65	8	250	60.5	188.5	107	249	40
1000A	1007	633	330	250	370	321	470	65	609	220	11	85	524	120	63	65	8	250	60.5	188.5	107	249	40
1250A	1007	633	330	250	370	321	470	65	609	220	11	85	524	120	63	65	8	250	60.5	188.5	107	249	40
1600A	1007	633	330	250	370	321	470	65	609	220	11	85	524	120	63	65	10	250	60.5	188.5	111	249	40

XQ5-200~3200A External Dimension and Installation Dimension

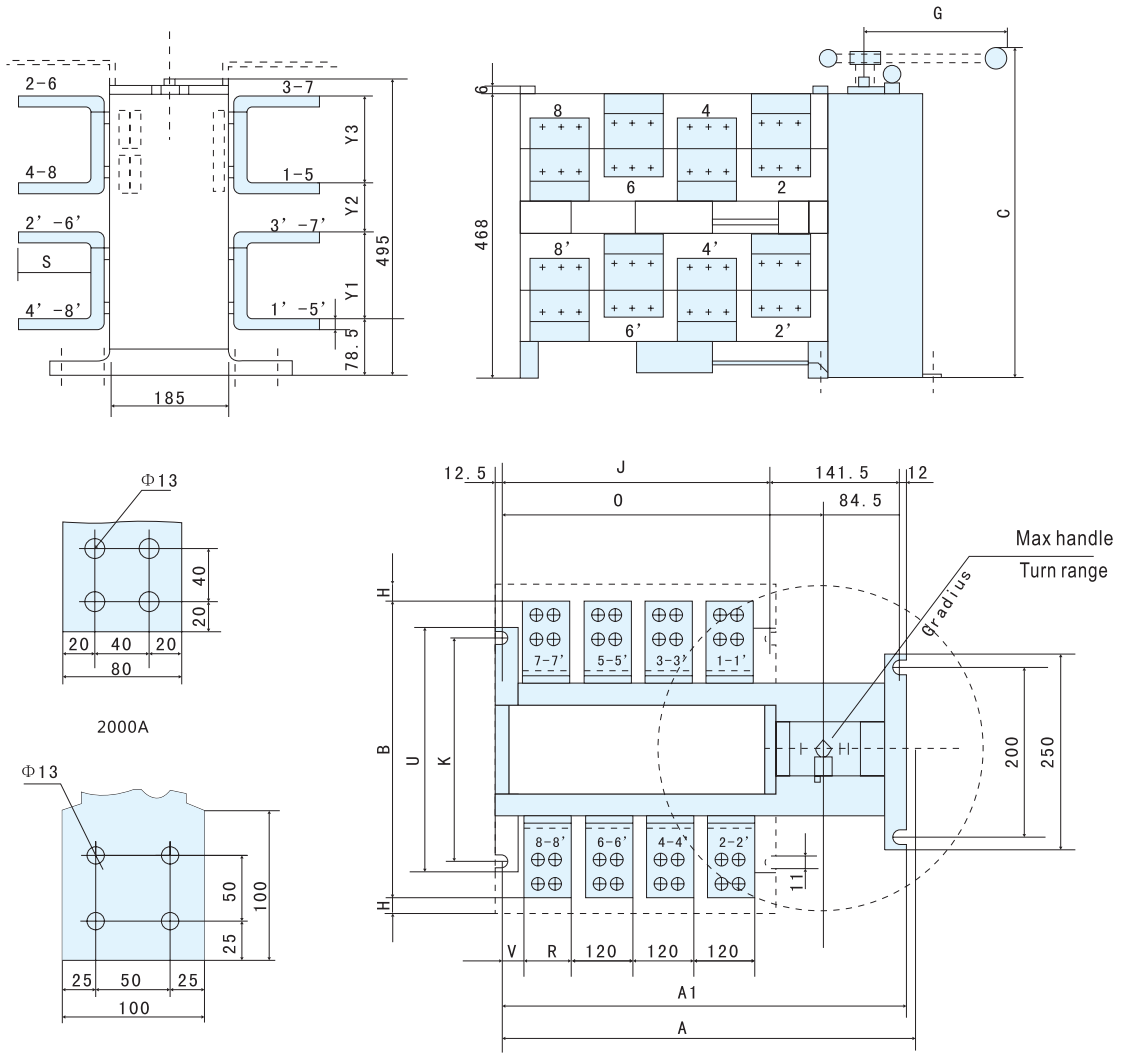

Specs	General dimension						On-Off installation						Terminal connection								
	A	A1	B	C	E	G	H	J	K	L	N	O	P	R	S	T	U	V	Y	Y1	Y3
2000A	1007	633	455	562	495	470	53	467	220	11	84.5	524	120	80	80	10	250	33	147	84	147
2500A	1007	633	455	562	495	470	28	467	220	11	84.5	524	120	80	100	10	250	13	152	79	152
3200A	1007	633	505	562	495	470	28	467	220	11	84.5	524	120	80	100	14	250	13	152	79	152

Cutoff function

1. Power supply changeover;

Main power supply changeover to emergency power.

2. Changeover,reverse:

Changeover between two load equipment.
(Emergency standby motor)reversion by two phases changeover.

3. Cutoff+the grounding

One operation of grounding and short circuit realizes the isolation(*) $(U_e > A_c)$

※General opening functions conform with the standards of IEC 947 and GB/T14048.

